

PAPER • OPEN ACCESS

Under Voltage Load Shedding Simulation for Southern Sulawesi Power System with Integration of Wind Power Plants

To cite this article: WS Wisna Saputri Alfira *et al* 2019 *J. Phys.: Conf. Ser.* **1175** 012128

View the [article online](#) for updates and enhancements.



IOP | ebooks™

Bringing you innovative digital publishing with leading voices to create your essential collection of books in STEM research.

Start exploring the collection - download the first chapter of every title for free.

Under Voltage Load Shedding Simulation for Southern Sulawesi Power System with Integration of Wind Power Plants

Wisna Saputri Alfira WS, Muhammad Bachtiar Nappu and Ardiaty Arief

¹Centre for Research and Development on Energy and Electricity, Hasanuddin University, Makassar 90245, Indonesia

²Department of Electrical Engineering, Faculty of Engineering, Hasanuddin University, Gowa 92119, Indonesia

Abstract. This paper discusses the simulation of under voltage load Shedding (UVLS) by considering the integration of wind power plants (WPP). The WPPs which will be integrated into the Southern Sulawesi interconnection system owned by PT. PLN (Persero) are located in the Sidrap area of approximately 70 MW using 30 wind turbines, generating 2.5 MW per turbine and in the Jenepono area of about 62.5 MW capacity with the same number of wind turbines. Different wind conditions may affect the power system causing a major or minor disturbance, either in a release of generation or a transmission line. Based on this issue, this study aims to perform a simulation on areas that have voltage collapse when the WPPs are in the Southern Sulawesi system. The method of dynamic sensitivity presented in this paper. From the simulation and analysis results, it is obtained that load shedding locations in Makale, Palopo and Latuppa can stabilize the system's voltage but causing the Poso area to be in an over voltage condition.

1. Introduction

The Southern Sulawesi interconnected power system owned by PT. PLN (Persero) will have additional power generation with the integration of wind power plants (WPPs) in Sidrap and Jenepono Regencies. These power plants that will be integrated into the system is according to General Plan of Electricity Supply (RUPTL) of PLN 2010 to 2019 in which the total generating capacity in Sidrap area of about 70 MW using 30 wind turbines, each generating 2.5 MW [1] whereas in the area Jenepono generate total electrical energy of 62.5 MW with 30 wind turbines [2]. The problem on the basis of the thermal power station is the wind conditions change depending on climatic conditions which lie in the area, then the source of energy converted to electricity in a constant state of the electricity generated is not constant. Hence, it is very influential on electric power systems.

In large-scale power systems, maintaining the continuity and availability of power supplies for consumers is the main objective of the interconnection system. References [3-5] have identified the stability of the power system as part of the most important and reliable prerequisites for the almost 1 to obtain safe operation of the electrical system. The operation of a power system is expected to maintain the system's stability since this problem that has become a major issue in the planning and operation of power systems [6] and is an important part in maintaining the continuous supply with good power quality by minimizing the occurrence of blackouts.



Voltage instability is the inability of the power system to maintain voltage profile at all buses within the permitted limit after a system failure or change that can bring the entire network system to a significant voltage drop condition [7]. One way to keep the system voltage stability under undesirable conditions is by performing load shedding when a severe instability occurs. Load shedding is an economical preventive action in reducing the voltage/frequency drop of the system. Load shedding should be done in the right location, so that it can increase the voltage significantly into tolerable tolerance range of + 5% and -10% of nominal voltage [7-9]. As a basis for the guidance to design an under voltage load shedding (UVLS) scheme is proposed by H. G. Sarmiento, et al [10].

Over the time, various methods have been proposed for UVLS. The early appearance of the UVLS concept was in 1992 by Taylor [11] to offer additional protection action along with under-frequency load shedding (UFLS) for abnormal interference beyond system's operational and planning criteria. Then UVLS schemes and methods progressed with various approaches, such as in paper [12-13], where the method is to calculate the dynamic sensitivity associated with the interference so that the track sensitivity between bus voltages can be calculated to obtain sufficient quantities to shed the load at the appropriate location. Another method of UVLS in power systems has been applied by assessing the integration of doubly fed induction generators (DFIG) to maintain voltage stability by considering dynamic and static load modelling involving an iteration algorithm [14]. Paper [3] also simulated UVLS to a 3 9-bus engines and then performs dynamic simulation for validation of bus participation method. Furthermore, study in [15] performed the calculation of eigenvalues to determine the pickup voltage for tripping signals, where the eigenvalues were used to measure global indices so that the voltage drop and voltage magnitude of the critical bus can be determined. Researchers in [16, 17] conducted a study that considered contingent critical for load shedding optimization based on participating factor capital. The participation factors capital in this study was used in finding the most suitable bus for load shedding location. References [18, 19] developed UVLS strategies with dynamic load generic models. In Amraee's paper [20], a UVLS design with a distribution generator (DG) was proposed, but this study used only static voltage analysis approach and did not consider DG type. Dynamic voltage stability is important in UVLS design since system behavior will result in substantial changes after disruption due to DG technology and different conventional generators [21, 22].

In this paper, we simulated dynamic voltage sensitivity analysis in designing UVLS schemes to determine the location and size of the load to be removed in case of major disturbances in the system with the integration of the WPP into the Southern Sulawesi power system. The dynamic voltage performances were analyzed before and after the Sidrap and Jeneponto's WPP integration.

2. Under-Voltage Load Shedding

Under-Voltage Load Shedding (UVLS) is any load release mechanism due to low system voltage below the limit of tolerance -10% of value [23-24], UVLS is a protection scheme aims to remove the load on the transformer side so that the voltage on the distribution system can rise to normal conditions.

Releasing the load on distribution transformer side with UVLS scheme has several stages. It consider the condition of the transformer load distribution. As for consideration includes two aspects, namely:

- 1) Technical aspects
 - a) UVLS scheme needs to consider the minimum system voltage levels at other plants
 - b) The length of time the power plants can survive when the system voltage down continuously.
 - c) Ability of generator exciter at the weakest point
- 2) Non-Technical Aspects. Because UVLS requires performing an interruption on the consumers, then it is very important to consider which consumers should be turned off. Power supply continuity to consumers with high priority levels should be maintained.

The design of the load shedding should be robust. There are two steps power system defense against incidents that may trigger instability caused by system pressure [25-27]:

- In observing the margins of a security system, preventive actions need to be performed by considering different contingency possibilities and then perform the appropriate action as a solution to maintain a margin system.
- For the sake of minimizing the possibility of the risk of more severe events, it is necessary to execute correctively action by utilizing automatically repairing applications with a protection scheme.

The philosophy of UVLS is that every time the system is being disrupted and cause the voltage drop condition below a pre-selected predetermined voltage level for a certain time period, then some selected load should be removed [28]. The purpose of UVLS to restore the balance of power in the system, to avoid voltage collapse and regulate voltage problems [29-31].

3. Doubly Fed Induction Generator

Doubly fed induction generator (DFIG) is one kind of the WPPs. DFIG has several advantages, such as variable speed operation to get the maximum power extracted from the wind, the power factor can be adjusted, better efficiency, the ability to control reactive power without the support capacitive converter and a smaller rating [32-35].

Mechanical power from wind turbines converted by DFIG is sent to the power system through rotor and stator winding [36]. DFIG wind turbine is connected to the gearbox via the converter and voltage source back-to-back [37]. The gearbox is a very important device to control the diversity of various speed between rotor and generator. Stator winding of DFIG and the other side a supply of the rotor converter is connected to the power system. The voltage is maintained at a constant frequency while its amount is controlled by regulating the generator stator flux.

Technology configurations of DFIG are shown in Fig. 1 and Fig. 2 displays its equivalent circuit. By comparing the dynamic speed of the rotor flux and the stator dynamic network and the converter control system which separates the generator from the grid then the steady-state electric equations by considering DFIG become [38],

$$V_{ds} = -r_s i_{ds} + [(X_s + X_m) i_{qs} + X_m i_{qr}] \quad (1)$$

$$V_{qs} = -r_s i_{qs} - [(X_s + X_m) i_{ds} + X_m i_{dr}] \quad (2)$$

$$V_{dr} = -r_R i_{dr} + (1 - w_m) [(X_R + X_m) i_{qr} + X_m i_{qs}] \quad (3)$$

$$V_{qr} = -r_R i_{qr} + (1 - w_m) [(X_R + X_m) i_{dr} + X_m i_{ds}] \quad (4)$$

Active and reactive power that sent to the grid become,

$$P = v_{ds} i_{ds} + v_{qs} i_{qs} + v_{dc} i_{dc} + v_{qc} i_{qc} \quad (5)$$

$$Q = v_{ds} i_{qs} - v_{qs} i_{ds} + v_{dc} i_{dc} - v_{qc} i_{qc} \quad (6)$$

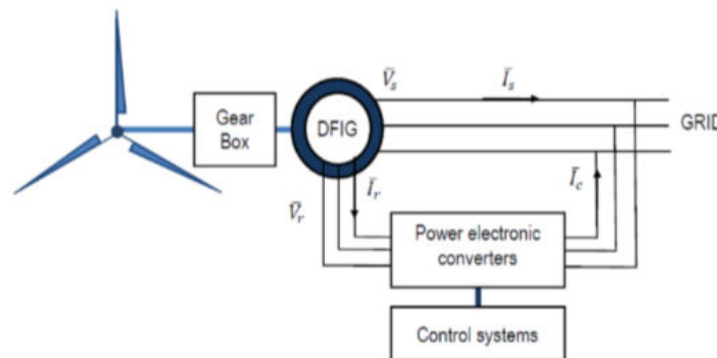

Figure 1. Configuration of DFIG [39]

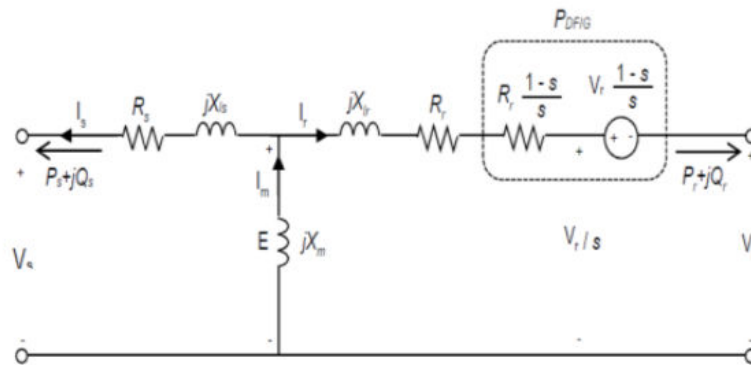

Figure 2. DFIG Equivalent Mode ^[12]

4. The Proposed Method

Fig. 3 shows the flowchart of the UVLS simulation as follows,

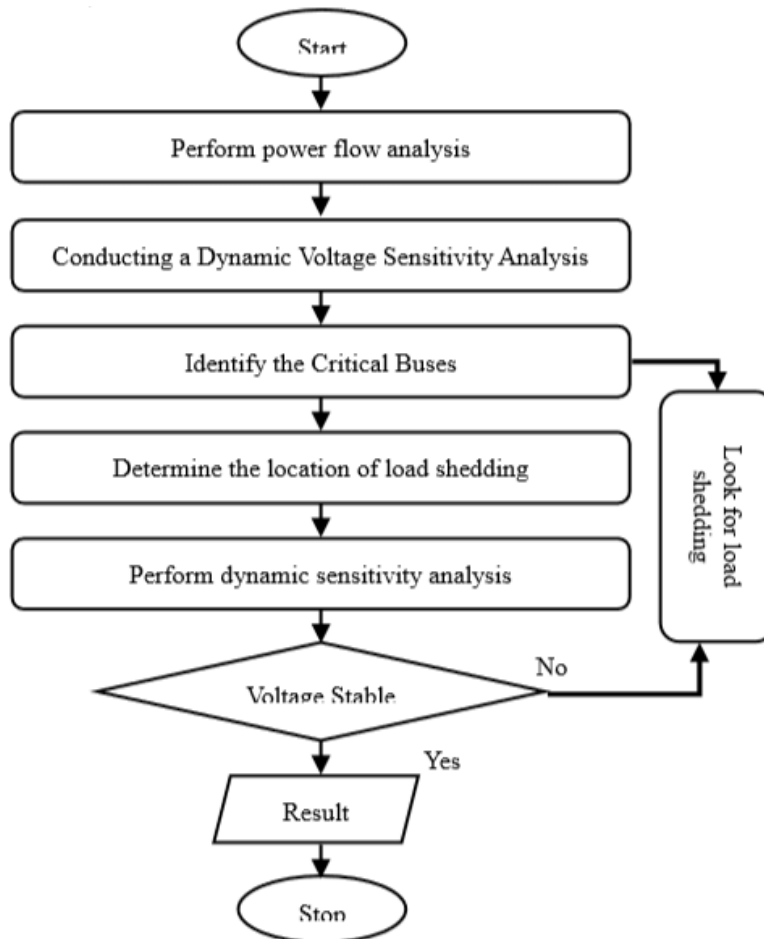

Figure 3. Flowchart UVLS Scheme

5. Simulations and Discussions

A. Voltage Simulation Prior to the Integration of Sidrap and Jeneponto WPPs

Initial simulation of voltage assessment conducted in this paper is condition before, the Sidrap and Jeneponto WPPs integrated into the Southern Sulawesi interconnected power system. The fault simulated occurs between bus Tello and bus Pangkep at time=0.01 second.

Fig. 4 shows the voltage profile when the simulated interference between the bus Tello and bus Pangkep the time interval $t = 0:01$ seconds. Results shows that some areas have voltage below 0.9 pu, showing the system becomes unstable but not causing voltage collapse.

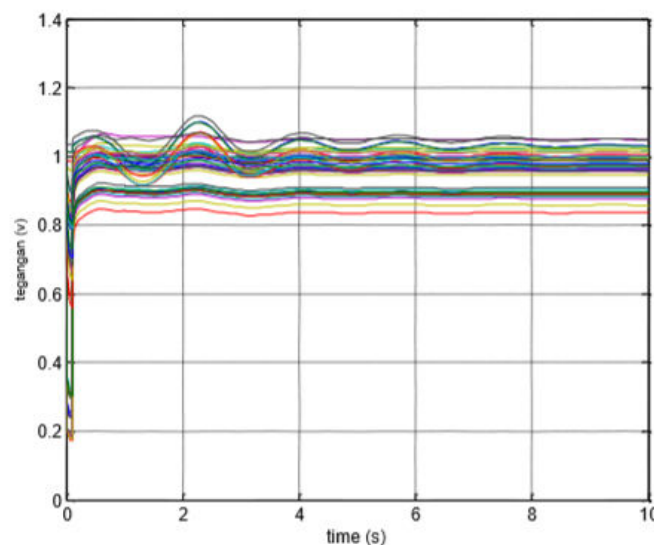

Figure 4. Voltage stability simulation after outage before integration of WPPs

B. Voltage Simulation After the Integration of Sidrap and Jeneponto WPPs

Fig. 5 shows the voltage drop/collapse at some areas in condition after the integration of Sidrap and Jeneponto WPPs when a fault occurs at bus between Pangkep and Tello. It can be seen from the graph that voltages at the bus Makale and bus Palopo suffer to collapse to 0 p.u at $t = 1.8$ seconds and were unable to return to a stable state. Furthermore, voltage at bus La Tuppa also is experiencing voltage drop to approximately 0.52 p.u. Some areas in Makassar also are having voltage instability with the magnitude just above 0.8 p.u. With many areas facing voltage instability and collapse, hence load shedding is necessary.

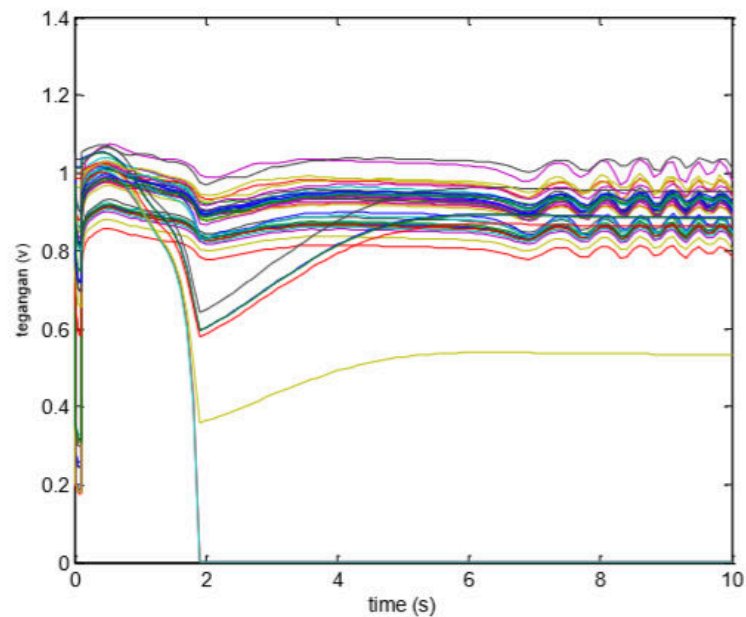

Figure 5. Voltage stability simulation after outage with integration of Sidrap and Jenepono WPPs

C. Voltage Simulation After Load Shedding at Makale and Palopo buses

Fig. 6 simulates voltage condition with integration of Sidrap and Jenepono WPPs after outage and load shedding at Palopo and Makale. It clearly shows that with load shedding at buses Makale and Palopo, the voltage at some areas cannot recover back its its stable condition, therefore it needs another location for load shedding.

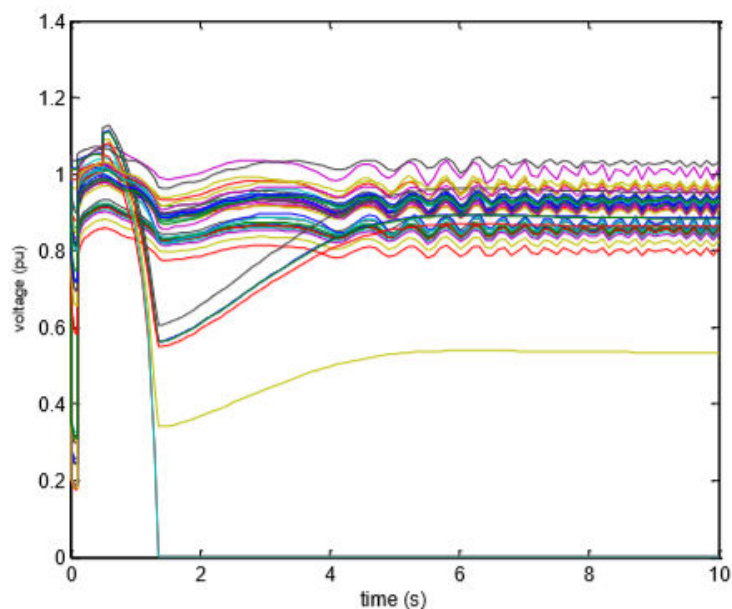

Figure 6. Voltage stability simulation with integration of Sidrap and Jenepono WPPs after outage and load shedding at Palopo and Makale

D. Voltage Simulation After Load Shedding at Makale, Palopo and Poso buses

Since load shedding at buses Palopo and Makale cannot stabilize the system, then more load should be shed. Fig. 7 shows the voltage simulation graph after load shedding at buses Makale, Palopo and Poso, but still cannot stabilize the system.

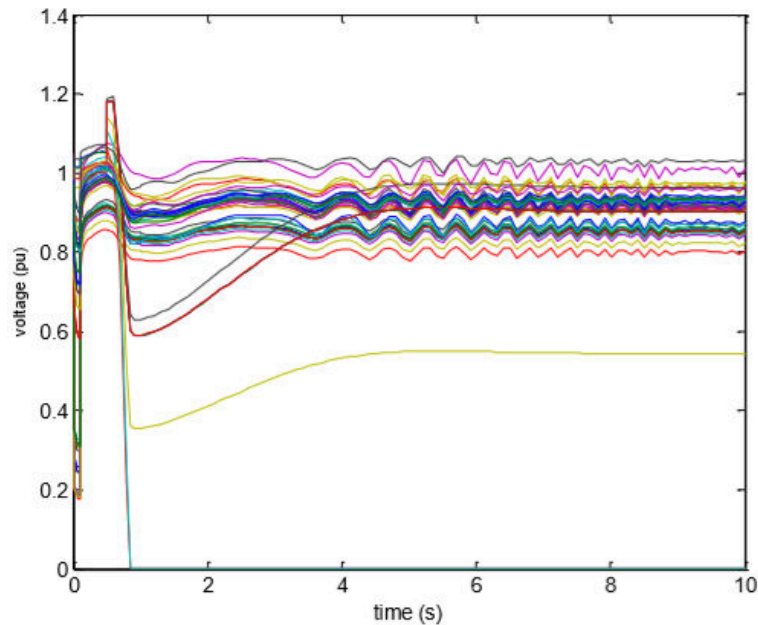

Figure 7. Voltage stability simulation with integration of Sidrap and Jenepono WPPs after outage and load shedding at Palopo, Makale and Poso

E. Voltage Simulation after Load Shedding at Makale, Palopo, and Latuppa buses

Fig. 8 shows voltage improvement after load shedding at buses Makale, Palopo and Latuppa. Voltage at buses Makale, Palopo and Latuppa are able to recover to above the stability limit, however, this load shedding scheme lead to another problem, that is a transient over voltage condition at bus Poso whose voltage at $t = 0.6$ becomes 1.4 p.u then dropped to 1.1 p.u at $t = 5.6$ seconds.

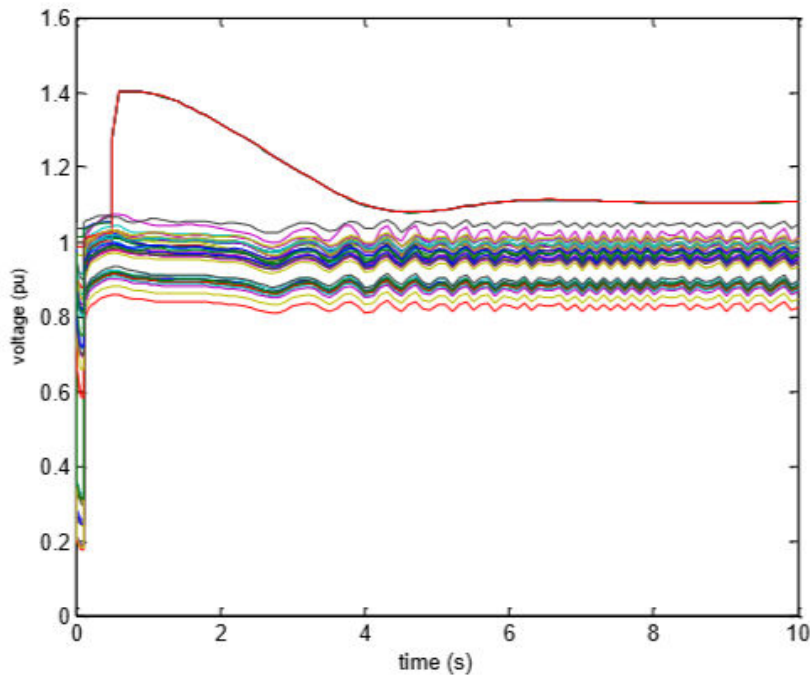

Figure 8. Voltage stability simulation with integration of Sidrap and Jenepono WPPs after outage and load shedding at Palopo, Makale and Latuppa

6. Conclusions

This research was conducted in the Southern Sulawesi interconnected power system considering the integration of wind power plants in the area of Sidrap and Jenepono. This study first assessed the voltage drop before and after the integration of WPPs. It shows that with the integration of WPPs, when outage occurs between bus Tello and Palopo, voltage at buses Makale, Palopo and Latuppa collapse. After several simulations, it is found that load shedding at buses Makale, Palopo and Latuppa is the most optimum so that voltage stability conditions can be back to normal condition eventhough a transient over voltage profile happens at Bus Poso.

Acknowledgments

The authors gratefully acknowledge the Indonesian Ministry of Research, Technology and Higher Education for providing the research grant and support in this work.

References

- [1] Kementrian ESDM Republik Indonesia, "PLTB Sidrap 70 MW Siap Dibangun," Direktorat Jendral Energi Baru Terbarukan dan Konservasi Energi (EBTKE), 2016.
- [2] Situs Resmi Kabupaten Jenepono, "Rapat Koordinasi Pembangunan Energi Terbarukan PLTB (Pembangkit Listrik Tenaga Bayu)," Jenepono, 2015.
- [3] A. Arief, M.B. Nappu, Z.Y. Dong and M. Arief, "Under Voltage Load Shedding Incorporating Bus Participation Factor", Proceedings of The 9th International Power and Energy Conference (IPEC), Singapore, 27 – 29 October 2010.
- [4] Z. Y. Dong, "Power System Dynamics and Stability, reference note For ME course on Power System Dynamics and Stability," UQ Publisher, 2007.
- [5] Z. Y. Dong and P. Zhang, "Emerging Techniques in Power System Analysis", Springer, 2009.

- [6] M. Klaric, I. Kuzle, and S. Tesnjak, "Example of Under Voltage Load Shedding Implementation," in IEEE AFRICON Conference, Windhoek, Namibia, 26-28 September, 2007, pp. 1-6.
- [7] P. Kundur, "Power System Stability and Control," New York: McGrawHill, 1994.
- [8] Y. Mansour and C. Canizares, "Voltage Stability," in Power System Stability and Control, L. L. Grigsby, Ed. Boca Raton: Taylor and Francis Group, 2007.
- [9] Agus R. Utomo and Dielita A. Malau, "Analisis Under Voltage load shedding Berdasarkan Nilai Sensitivitas Bus dan Daya Reaktif pada PT. PLN (Persero) APB DKI Jakarta & Banten," Universitas Indonesia, Depok, 2014.
- [10] H. G. Sarmiento, R. Castellanos, G. Pampin, G. Villa, and M. Mirabal, "Revisiting Undervoltage Load Shedding Schemes: A step by step approach," in Proc. IEEE/PES Transmission and Distribution Conference and Exposition, Chicago, USA, 21-24 april, 2008
- [11] C. W Taylor, "Concepts of Undervoltage Load Shedding for Volttage Stability," IEEE Transactions on Power Delivery , vol. 7, pp. 480-488, 1992.
- [12] A. Arief, Z.Y. Dong, M.B. Nappu, and M. Gallagher, "Under Voltage Load Shedding Utilizing Trajectory Sensitivity to Enhance Voltage Stability", Proceedings of the 21th Australasian Universities Power Engineering Conference (AUPEC), Brisbane, Australia, 25-28 September 2011.
- [13] A. Arief, M.B. Nappu, X. Yin, X. Zhou and Z.Y. Dong, "Under Voltage Load Shedding Design with Modal Analysis Approach", Proceedings of the 8th IET International Conference on Advances in Power System Control, Operation and Management (APSCOM), Hong Kong, 8-11 November 2009.
- [14] Ardiaty Arief, Z. Y. Dong, M. Bachtiar Nappu and M. Gallagher. "Under Voltage Load Shedding in Power System with Wind Turbine-driven Doubly Fed Induction Generators," Electrical Power Systems Research, vol. 96, pp. 91-100, 3// 2013.
- [15] M. Klaric, I. Kuzle, and S. Tesnjak, "Under Voltage Load Shedding using Global Voltage Collapse Index," in IEEE PESPower Systems Conference and Exposition, New York, USA, 10-13 October, 2004, pp. 453-459, vol. 1.
- [16] C. M. Affonso, L. C. P. da Silva, F. G. M. Lima, and S. Soares, "MW and MVar Management on Supply and Demand Side for Meeting Voltage Stability Margin Criteria," IEEE Transactions on Power System, vol. 19, pp.1538-1545, 2004
- [17] M.B. Nappu, A.Arief and R.C. Bansal, "Transmission management for congested power system: A review of concepts, technical challenges and development of a new methodology", Renewable and Sustainable Energy Reviews, Vol. 38, pp. 572-580, October 2014, <https://doi.org/10.1016/j.rser.2014.05.089>
- [18] R. Balanathan, N. C. Pahalawaththa, U. D Annakkage, and P. W. Sharp, "Undervoltage Load Shedding to Avoid Voltage Instability," IEE Proceedings Generation, Transmission and distribution, vol. 145, pp. 175181, 1998.
- [19] R. Balanathan, N. C. Pahalawaththa, and U. D Annakkage, "A Strategy for Undervoltage Load Shedding in Power System," in Proceedings International conference on Power System Technology, POWERCON Beijing, China, 18-21 August, 1998, pp.1494—1498 vol. 2.
- [20] T. Amraee, A.M. Ranjibar, B. Mozafari, and N. Sadati, "An Enchanced Under-Voltage load Shedding Scheme to Provide Voltage Stability," Electric power Systems Research, vol. 77, pp. 1038-1046, 2007.
- [21] C. Moors, D. Lefebvre, and T. Van Custem, "Design of Load Shedding Schemes Againts Voltage Instability," in IEER Power Engineering Society Winter Meeting, Singapore, 23-27 January, 2000, pp. 1495-1500, vol. 2.
- [22] A. Arief and M. B. Nappu, "Voltage Drop Simulation at Southern Sulawesi Power System Considering Composite Load Model", Proceedings of the 3rd International Conference on Information Technology, Computer and Electrical Engineering (ICITACEE 2016), Semarang, 19-20 October 2016

- [23] Tim Penyusun PLN. "Pedoman dan Petunjuk Sistem Proteksi Transmisi dan Gardu Induk Jawa Bali," PT. PLN (Persero), Jakarta, 2013.
- [24] Tim ESDM. "Aturan Jaringan Sistem Tenaga Listrik Sulawesi," PT. PLN (Persero) UPB Sulselrabar, Makassar, 2015.
- [25] C. Moors, D. Lefebvre, and T. Van Cutsem, "Design of Load Shedding Schemes Against Voltage Instability," in IEEE Power Engineering Society Winter Meeting, Singapore, 23-27 January, 2000, pp. 1495-1500, vol. 2.
- [26] D. Lefebvre, S. Bernard, and T. Van Cutsem, "Undervoltage Load Shedding Scheme for the Hydro-Quebec System," in IEEE Power Engineering Society General Meeting, Denver, Colorado, USA, 6-10 June, 2004, pp. 1619-1624 Vol.2.
- [27] M.B. Nappu and A.Arief, "Network Losses Reduction Due To New Hydro Power Plant Integration," Proceedings of the 3rd International Conference on Information Technology, Computer and Electrical Engineering (ICITACEE 2016), Semarang, 19-20 October 2016
- [28] M. Begovic, D. Fulton, M. R. Gonzalez, J. Goossens, E. A. Guro, R. W. Haas, C. F. Henville, G. Manchur, G. L. Michel, R. C. Pastore, J. Postforoosh, G. L. Schmitt, J. B. Williams, K. Zimmerman, and A. A. Burzese, "Summary of "System Protection and Voltage Stability"," IEEE Transactions on Power Delivery, vol. 10, pp. 631-638, 1995.
- [29] C. J. Mozina, "Undervoltage Load Shedding," in 60th Annual Conference for Protective Relay Engineers Texas, USA, 27-29 March, 2007, pp. 1634.
- [30] M.B. Nappu, R.C. Bansal and T.K. Saha, "Market power implication on congested power system: A case study of financial withheld strategy", International Journal of Electrical Power & Energy Systems, Vol. 47, pp. 408-415, May 2013, <https://doi.org/10.1016/j.ijepes.2012.09.016>
- [31] A. Arief, M.B. Nappu, Z.Y. Dong and M. Arief, "Load Curtailment Strategy in Distribution Network with Dispersed Generations", Proceedings of the 21th Australasian Universities Power Engineering Conference (AUPEC), Brisbane, Australia, 25-28 September 2011.
- [32] M.B. Nappu and A. Arief, "Network Losses-Based Economic Redispatch for Optimal Energy Pricing in a Congested Power System", Energy Procedia, ELSEVIER, Volume 100, November 2016, Pages 311-314, <https://doi.org/10.1016/j.egypro.2016.10.183>.
- [33] E. Vittal, M. O'Malley, and A. Keane, "A Steady-State Voltage Stability Analysis of Power Systems With High Penetrations of Wind," IEEE Transactions on Power Systems, vol. 25, pp. 433-442, 2010.
- [34] H. Nian, Y. Song, P. Zhou, and Y. He, "Improved Direct Power Control of a Wind Turbine Driven Doubly Fed Induction Generator During Transient Grid Voltage Unbalance," IEEE Transactions on Energy Conversion, vol. 26, pp. 976-986, 2011.
- [35] B. A. Chen, T. K. Lu, Y. Y. Hsu, W. L. Chen, and Z. C. Lee, "An Analytical Approach to Maximum Power Tracking and Loss Minimization of a Doubly Fed Induction Generator Considering Core Loss," IEEE Transactions on Energy Conversion, vol. 27, pp. 449-456, 2012.
- [36] H. Xu, J. Hu, and Y. He, "Operation of Wind-Turbine-Driven DFIG Systems Under Distorted Grid Voltage Conditions: Analysis and Experimental Validations," IEEE Transactions on Power Electronics, vol. 27, pp. 2354-2366, 2012.
- [37] C. H. Liu and Y. Y. Hsu, "Effect of Rotor Excitation Voltage on SteadyState Stability and Maximum Output Power of a Doubly Fed Induction Generator," IEEE Transactions on Industrial Electronics, vol. 58, pp. 1096-1109, 2011.
- [38] C. Chompooinwai, C. Yingvivanapong, K. Methaprayoon, and W. J. Lee, "Reactive Compensation Techniques to Improve the Ride-Through Capability of Wind Turbine During Disturbance," IEEE Transactions on Industry Applications, vol. 41, pp. 666-672, 2005.
- [39] F. Milano, Power System Analysis Toolbox, 2005.